

Key to Efficient Automation



# The Key to Efficient Automation



## M90 & M91 Micro-OPLCs



**Operator Panel and Programmable Logic Controller**



# The M90

## Is it an HMI? Is it a PLC?

### It's Both.

#### The M90 & M91

#### Each Micro PLC includes:

- Onboard I/O configuration.  
Add I/Os via a range of I/O expansion modules
- Integral HMI, including LCD & keypad  
M91 LCD: 2 16-character text lines  
M90 LCD: 1 16-character text line

#### Perfect control for any application

- Water treatment
- Alarm systems
- Traffic signal control
- Automated production
- Process control (thermal, level, pressure)



GSM Control



Building and Environment control

Conveyor belts



Packaging



Analog output



Oven control

RS232/RS485





High-speed counters

pnp/npn Digital inputs



Analog/  
Thermocouple/  
PT100 inputs

MODBUS (M91) CANbus (M90/M91)



4 PID Loops with  
internal auto-tune



Pump  
management



Energy control



High-speed outputs



Transistor/Relay outputs



Expansion Modules



Up to 96 additional I/Os



# Communication & Networking

ALARM: Te

## SMS Control

Use your GSM cell phone to implement real-time remote control in your application.

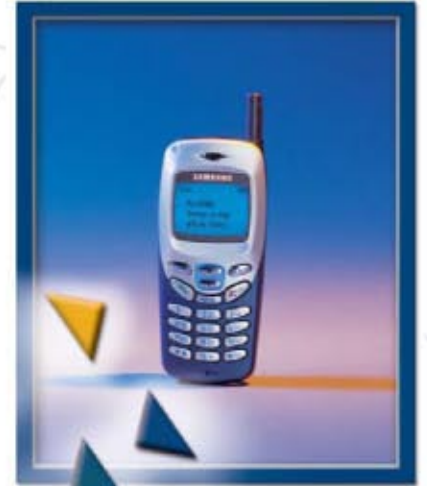

### Remote control:

Send SMS messages from your GSM phone to monitor and modify set-points or run-time parameters in your system.

### Remote trouble-shooting:

The M90/M91 can send SMS messages to your GSM cell phone to notify you of system faults.



## The GSM-enabled M90/M91:

- Sends and receives SMS messages containing both fixed text and variable data
- Sends messages to different GSM cell phones
- Can route different messages to different phone numbers
- Protects your system: prevents unauthorized callers
- Auto-acknowledges received messages
- Answers data requests from your cell phone
- Contains up to 1k of user-defined messages
- Sends system updates to any local or remote serial printer, via GSM

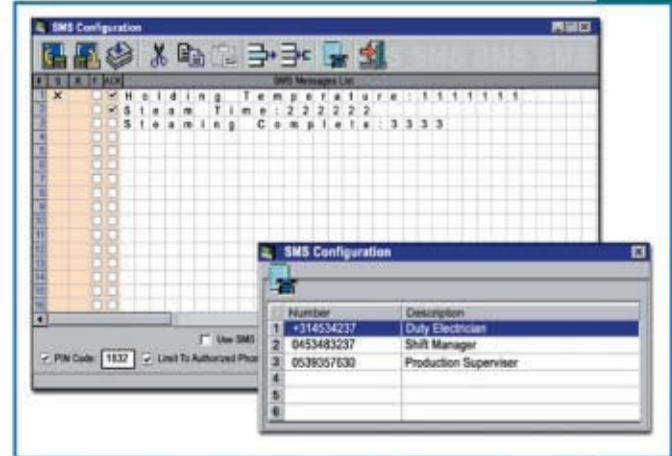

## Remote GSM control requires:

**An M90/M91 unit (one of the 12 GSM-enabled models) plus a GSM kit; a selection of modems is available.**

### The kit includes:

- GSM modem
- Magnetic antenna and cable
- PLC to modem adapter
- Power supply cable



# Remote Access utilities

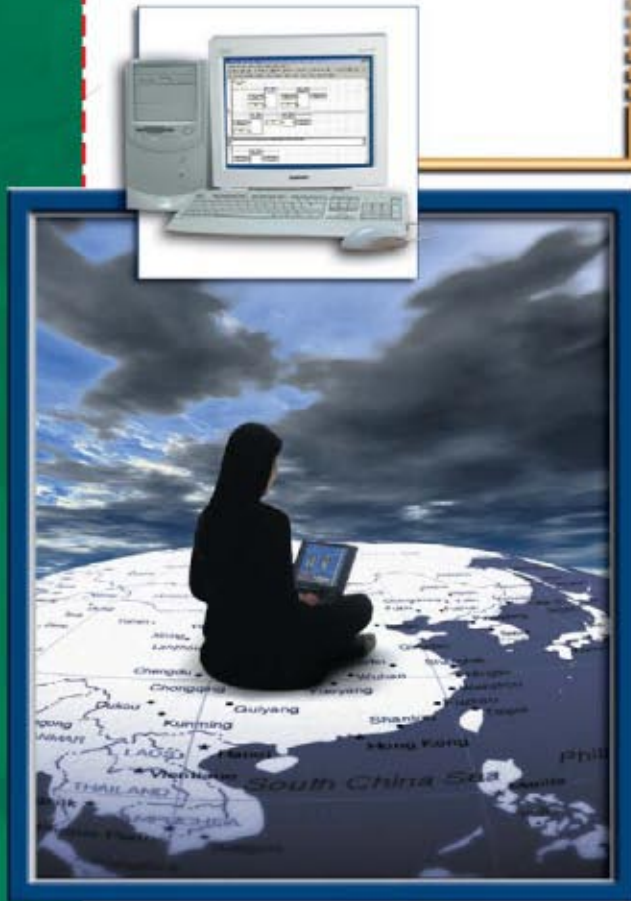

### Access remote M90/M91 controllers via GSM or landline modem.

- Download, upload, or debug remote M90/M91 programs
- Operate the controller's panel via remote PC
- View real-time parameters
- View and operate several controllers on your PC screen, simultaneously, in real-time
- Read, write, and store online operand values
- Run, reset, or initialize a remote controller

**Remote Access can run independently of the Ladder software, thereby protecting your program from unauthorized users**



# DataXport

**This powerful software utility captures PLC application data, then exports it to Excel files for processing.**

**Data is exported according to a user-defined schedule.**



Date	Time	Pump No.	Status	Invert
11/01/00	13:05	40	0	0
11/01/00	13:05	40	1	1
11/01/00	13:05	34	0	0
11/01/00	13:06	7	0	0
11/01/00	13:06	11	0	0
11/01/00	13:06	16	1	1
11/01/00	13:06	21	0	0
11/01/00	13:06	27	0	0
11/01/00	13:06	40	1	0
11/01/00	13:06	47	1	1
11/01/00	13:06	52	0	0
11/01/00	13:07	0	0	0
11/01/00	13:07	9	1	0
11/01/00	13:07	27	1	1
11/01/00	13:07	36	0	0
11/01/00	13:07	41	0	0
11/01/00	13:08	52	1	0
11/01/00	13:09	56	1	1
11/01/00	13:09	1	0	0
11/01/00	13:09	5	0	0
11/01/00	13:09	7	1	0
11/01/00	13:09	10	1	1
11/01/00	13:09	12	0	0
11/01/00	13:09	13	0	0
11/01/00	13:09	20	1	0
11/01/00	13:09	25	1	1
11/01/00	13:09	26	0	0
11/01/00	13:09	28	1	0
11/01/00	13:09	31	0	1
11/01/00	13:09	36	1	1
11/01/00	13:09	42	1	1
11/01/00	13:09	43	0	0



## Use DataXport to:

- Log PLC application data to Excel according to a date/time-based schedule
- Simultaneously log data from one or more Unitronics PLCs, whether networked or stand-alone
- Access PLCs and log data either directly, via network or via GSM/landline modem connection
- Pull data manually, to view current parameter status





# MODBUS

Use MODBUS\* to create a multi-device network, and establish master-slave communication between M91 OPLC™ units and any connected device that supports the MODBUS protocol (SCADA systems, servos and other peripheral devices). Networks can also include Vision graphic OPLC™ units. Any M91 in the network may function as either master or slave.

\*MODBUS is a feature of the M91 line



# CANbus

Do you need a distributed control system?  
CANbus enables efficient inter-PLC data exchange on your network. Use Unitronics' CANbus protocol to integrate up to 63 M90/M91 units into one high-speed network. Networks can include Vision Graphic OPLC™ units.



# RS232/RS485



Use RS232/RS485\* to:

- Gain PC access to stand-alone and networked controllers
- Communicate with external serial devices, such as modems, and serial printers
- Implement MODBUS commands with any MODBUS-supported device

\*RS485 is a feature of the M91 line

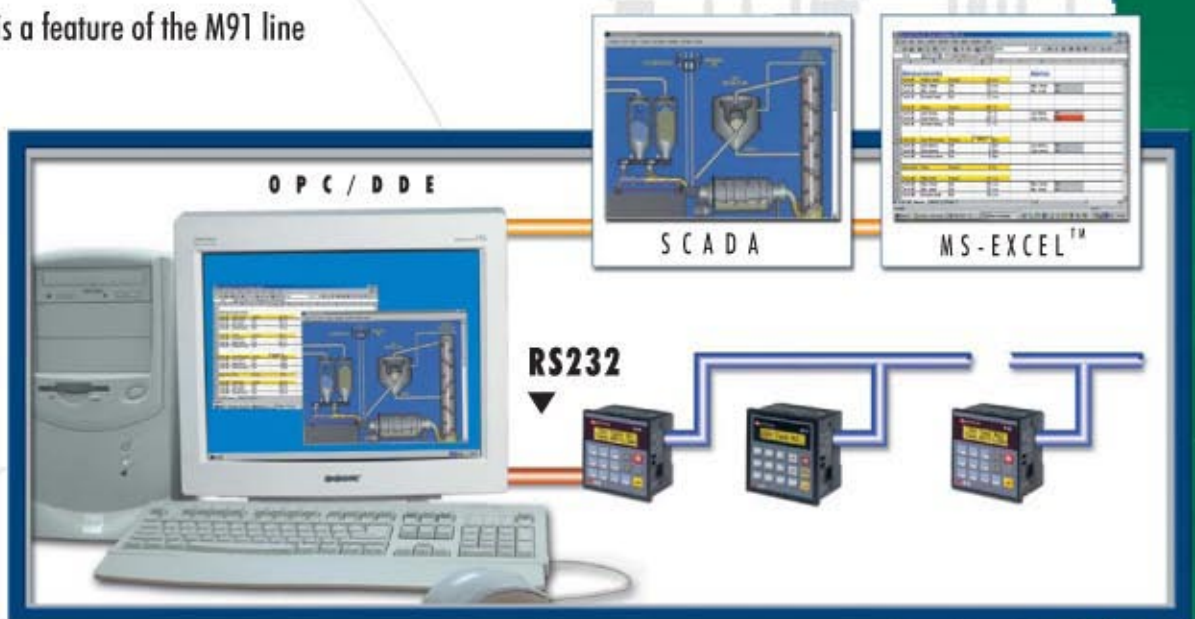

## OPC Server

Unitronics' OPC/DDE Server enables the OPLC™ to exchange data with any Windows-based application. Use it to interface with SCADA systems, or to Read/Write PLC data from/to Excel, Access or other applications.



# Expand your I/O capacity

## Mechanical dimensions

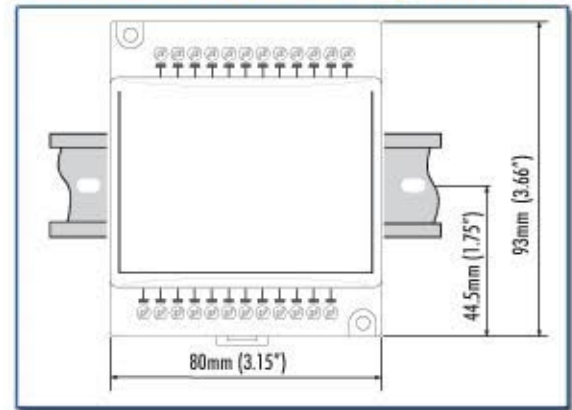

## DIN-rail mounting

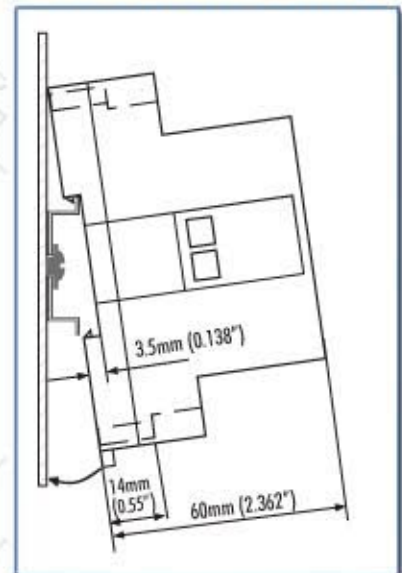

## Plug-in I/O expansion modules increase your control—and control your budget.

- Add up to 96 digital I/Os
- Additional analog I/Os, temperature and weight measurement inputs
- Up to 8 modules may be connected to a single M90/M91, via an expansion adapter
- DIN-rail or screw mounting

## Screw mounting

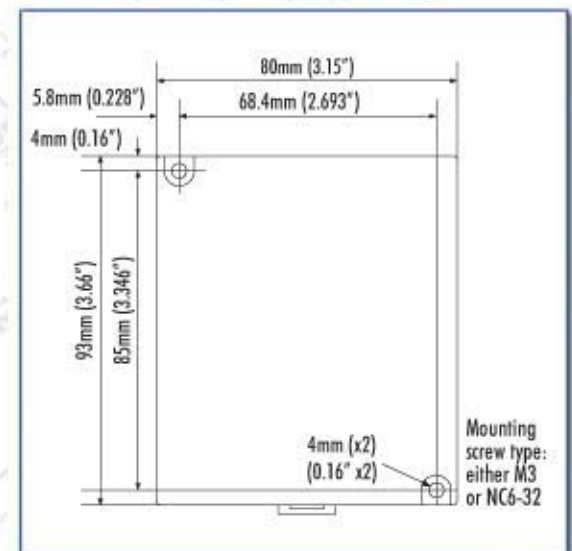

# 21 Compact I/O Expansion models:



## Digital modules

 <p><b>IO-DI8-T08</b> 24VDC 8 Digital Inputs, pnp/npn, including one High-speed Counter 8 pnp Transistor Outputs</p>	 <p><b>IO-R08</b> 24VDC (power supply) 8 Relay Outputs</p>
 <p><b>IO-DI8-R08</b> 24VDC 8 Digital Inputs, pnp/npn, including one High-speed Counter 8 Relay Outputs</p>	 <p><b>IO-R016</b> 24VDC (power supply) 16 Relay Outputs</p>
 <p><b>IO-DI8-R04</b> 24VDC 8 Digital Inputs, pnp/npn, including one High-speed Counter 4 Relay Outputs</p>	 <p><b>EX90-DI8-R08'</b> 24VDC 8 Digital Inputs, pnp/npn, including one High-speed Counter 8 Relay Outputs</p>
 <p><b>IO-DI16</b> 24VDC 16 Digital Inputs, pnp/npn, including one High-speed Counter</p>	 <p><b>IO-DI8ACH</b> 110/220 VAC 8 AC Inputs</p>
 <p><b>IO-T016</b> 12/24VDC 16 pnp Transistor Outputs</p>	 <p><b>EX-A1</b> Expansion adapter. Used to link between the PLC and up to 8 expansion modules. Supports both 12/24VDC.</p>

## Analog and Temperature measurement

 <p><b>IO-AI4-A02</b> 24VDC (power supply) 4 Analog Inputs, 12 bit, 0-10V, 0-20mA, 4-20mA, 2 Analog Outputs, 12 bit + sign ± 10V, 0-20mA, 4-20mA</p>
 <p><b>IO-A06K</b> 24VDC (power supply) 6 Isolated Analog Outputs, 0-10V, 0-20mA, 4-20mA 12 bit</p>
 <p><b>IO-PT4</b> 4 PT100 Inputs, Range: -50°C ÷ 460°C, (-58°F ÷ 860°F) 12 bit</p>
 <p><b>IO-PT4K²</b> <span style="color: red; font-weight: bold;">NEW</span> 4 PT1000/NI1000 Inputs, Range PT1000: -50°C ÷ 460°C (58°F ÷ 860°F) Range NI1000: -50°C ÷ 232°C (58°F ÷ 449°F) 12 bit</p>
 <p><b>IO-ATC8</b> 8 Thermocouple/ Analog Inputs, T/C J, K, T, B, E, N, R, S, 0-1° Resolution, 0-10V, 0-20mA, 4-20mA, 12/14 bit</p>

## Weight/Strain measurement

 <p><b>IO-LC1¹</b> <b>IO-LC3²</b> 12/24VDC (Power Supply) 1-3 Loadcell / Strain gauge Inputs Input voltage ranges: ± 20mV, ± 80mV Excitation: AC/DC 1 Digital pnp Input 2 Setpoint pnp Outputs <i>*Not supported by all OPLCs™ (Note 3).</i></p>
--

<sup>1</sup> The EX90 is housed in an open casing. Only one EX90 can be connected per PLC, as a single expansion module; EX-A1 adapter not required.

<sup>2</sup> IO-PT4K is not yet UL certified.

<sup>3</sup> IO-LCx models are currently supported by the M91 & Vision series; IO-LCx is not supported by the M90 series. IO-LCx is not yet UL certified.

12VDC is supported by these models:

IO-DI8-T08-L, IO-DI8-R04-L, IO-DI8-R08-L, IO-DI16-L, IO-R08L, IO-R016-L.

IO-PT4, IO-PT4K & IO-ATC8 support any voltage.







# Integrated HMI: A built-in advantage



## Economical

- Cuts programming time
- Less wiring
- Saves space

## Convenient

- A single programming environment for both PLC and HMI applications

## Reliable

- Built-in Panel-PLC communication

## Use the operator panel to:

- Display conditional messages- Multilingual support available
- Insert data via the M90/M91 keypad
- Show time, date, bit status, timer and integer values (Up to 64 HMI variables)
- Display up to 80 user-designed screens
- Add display power: "List" Variables add up to 2K's worth of HMI capacity
- View I/O status, integer values, and system data via Info mode

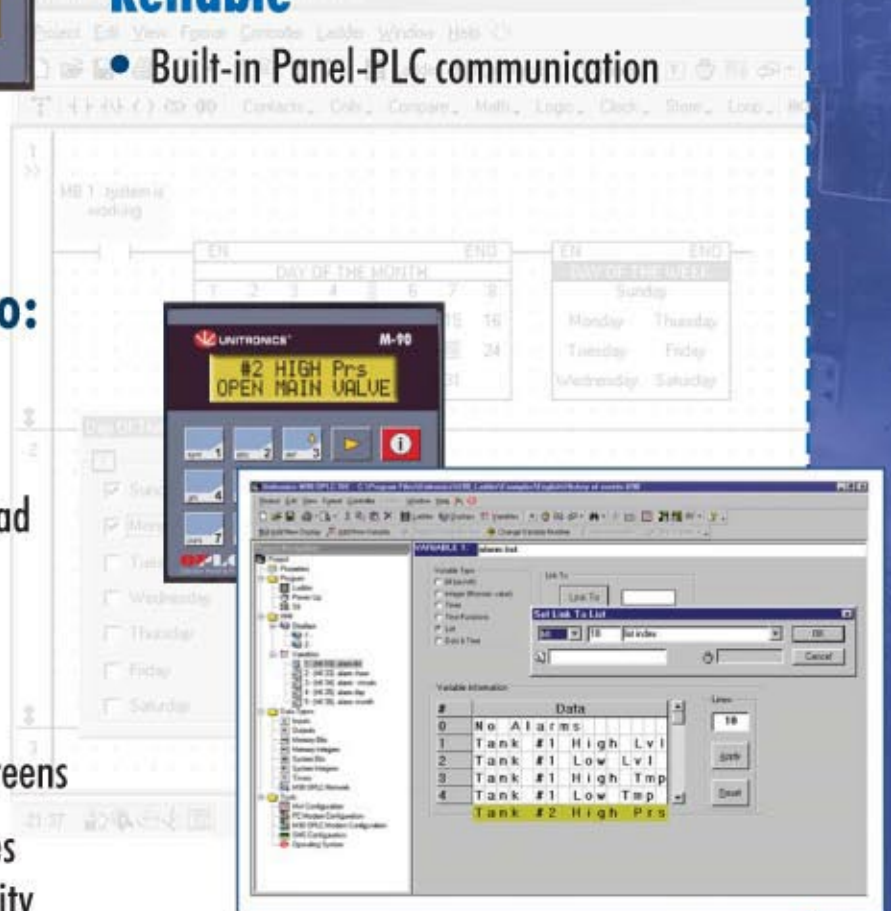



# A world of features



## High-speed output

### Step on it:

Choose any one of the 5 M90/M91 models that include **high-speed outputs** (1.5 to 2 kHz), to control your Stepper motor or PID based application, via PWM.

## Shaft encoder

### Speed up!

Use the M90/M91's **high-speed counters/shaft encoders/frequency measurers**. Up to 3 integral 10 kHz high-speed counters/frequency measurers or direct connections to shaft encoders in any M90/M91 unit.



## Print via RS232



### Print it out!

Put system data and log events on paper with the **Print** utility. The M90/M91 can send regular or event-provoked messages to any serial printer, either directly or via GSM/landline modem.

## 4 PID loops with internal auto-tune<sup>1</sup>

### Flexible PID.

Built-in 4 **PID** loops with internal auto-tune<sup>1</sup>. The M90/M91's direct PT100/Thermocouple inputs, analog or high-speed I/Os enable you to establish highly flexible process control.

<sup>1</sup>Internal auto-tune is available in M91 series. Auto-tune via an external PC-based application is available in M90 and M91 series.





## Time-based control



### Mark the calendar:

Do you need a specific task to be performed at a specific time and date?

Simply mark the hour, weekday and date in your program, and you have **time-based control**.

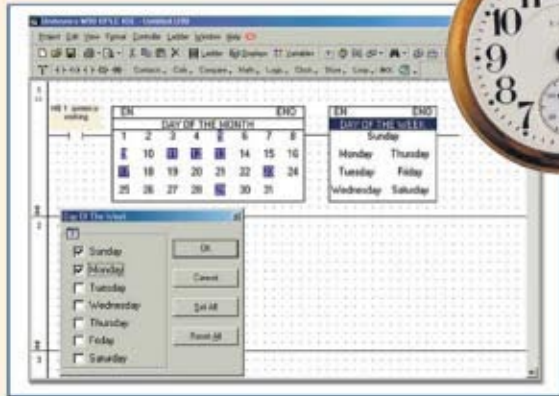

## List variable

### Choose a recipe:

Define recipes/menus for different tasks. The **List Variables** enable you to easily scroll, choose and activate the desired task via the HMI.



## Upload

### Misplaced the program? Don't know which version is it?

**Upload** the program from the PLC's Flash memory. Password-protected **Full source** upload option enables you to restore the application, as if it was just saved on your PC (including notes, remarks and symbols).

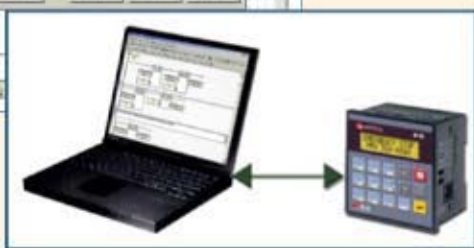
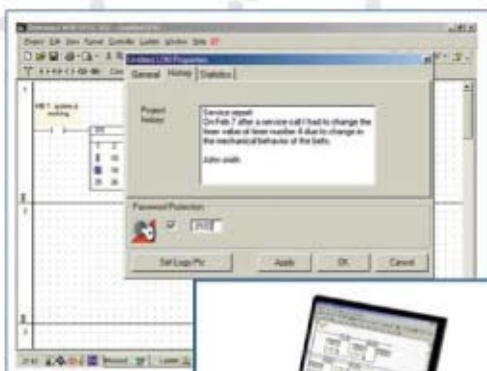

## Database

### Keep track.

Do you need to record production quantities?  
Record temperature to monitor refrigeration?

You need the M90/M91's **database** – 1024 integers, to log any required data.

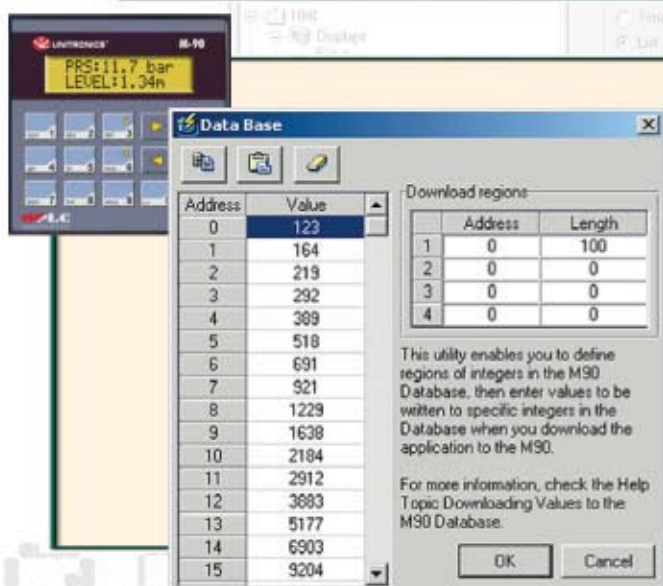

\*Certain features may vary according to model.



# All in One Package:



- ▶ **OPLC™ Controller**
- ▶ **U90 Ladder software**
- ▶ **Panel-mounting brackets**
- ▶ **Rubber seal for panel-mounting**
- ▶ **Programming cable**
- ▶ **Plug-in I/O connectors**
- ▶ **5 pin plug-in CANbus connector (for CAN models)**
- ▶ **Terminating resistor (for CAN models)**

## M90/M91 dimensions and mounting

### DIN-rail snap-mounted

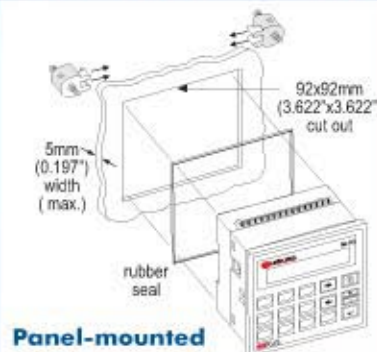
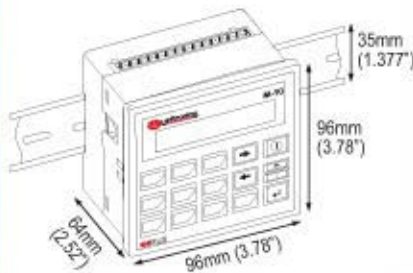

Panel-mounted

### Mechanical dimensions

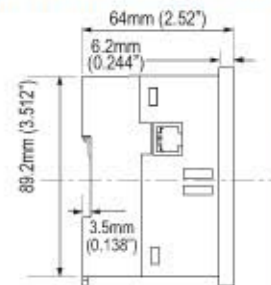

## M90/M91 optional accessories:

- **GSM Kits**
  - Article No.: GSM-KIT-14J (including Siemens TC65T modem)
  - Article No.: GSM-KIT-24J (including Wavecom modem)
  - Article No.: GSM-KIT-12 (including Siemens TC35 modem)
- **Power supply for GSM modem (for Siemens modems)**  
Article No.: PS-GSM-220V
- **RS232 communication cable for GSM modem (modem to PC)**
  - Article No.: MJ10-22-CS32, for Wavecom
  - Article No.: MJ10-22-CS28, for Siemens modems  
(Already included in GSM-KIT-14J)
- **I/O expansion cable, length 0.5 to 6m**  
Article No.: EX1-CA050 to EX1-CA600
- **Power supply**  
1.1 Ampere, 24V Switching Power Supply.  
DIN-rail or surface mounted.  
Article No.: PS-24-11A
- **RS232 to RS422/485 converter**  
Article No.: M90-19-R4
- **RS485 connector (for M91/V120 series)**  
Article No.: MJ10-22-CS66
- **USB to RS232 converter**  
Article No.: MJ10-22-CS35



# About Unitronics



Unitronics designs, manufactures and markets quality PLCs for the global market.

Easy to use, efficient and affordable, our products have been automating processes and stand-alone applications since 1989.

Via our Israeli headquarters and U.S. subsidiary, Unitronics supports a global marketing network of over 100 distributors.

Unitronics' field-proven OPLC™ controllers automate many thousands of installations in diverse fields: petrochemical, automotive, food processing, plastics and textile, energy and environment, water and wastewater management: anywhere automated processes are required.



## Our clients include:

- **Coca-Cola**
- **General Motors**
- **Michelin**
- **Tupperware**
- **Intel**
- **Bayer**
- **Colgate-Palmolive**
- **Bosch-Rexroth**
- **ABB**
- **Land Instruments**
- **Mercedes**
- **Agfa**
- **Tyson Foods**
- **Pirelli**
- **Fiat**
- **Samsonite**



# Technical specifications

	M90-T	M90-TA2-CAN	M90-19-B1A	M91-2-R1	M91-2-R2C	M91-2-R6C
	8 Digital Inputs 6 Transistor Outputs	10 Digital Inputs 8 Transistor Outputs 2 Analog Inputs 1 Analog Output	10 Digital Inputs 6 Relay Outputs 1 Analog Input	10 Digital Inputs 6 Relay Outputs 1 Analog Input	10 Digital Inputs 6 Relay Outputs 2 Analog Inputs	6 Digital Inputs 6 Relay Outputs 6 Analog Inputs
<b>Inputs</b>						
Digital inputs	8 pnp (source) 24VDC	10 pnp (source) 24VDC	10 pnp (source) 24VDC	10 pnp/npn (source/sink) 12/24VDC	10 pnp/npn (source/sink) 12/24VDC	6 pnp/npn (source/sink) 24VDC
High-speed counter/ Shaft-encoder/ Frequency measurer <sup>3</sup>	One 10 kHz, 16 bit resolution	One 10 kHz, 16 bit resolution	One 10 kHz, 16 bit resolution	Three 10 kHz, 16 bit resolution	Three 10 kHz, 16 bit resolution	One 10 kHz, 16 bit resolution
Analog input types	None	Two 10 bit inputs: 0-10V	One 10 bit input: 0-5V, 0-10V, 0-20mA, 4-20mA	One 10 bit input: 0-10V, 0-20mA, 4-20mA	Two 10 bit inputs: 0-10V, 0-20mA, 4-20mA	Six 10 bit inputs: Two 0-10V, 0-20mA, 4-20mA Four 0-20mA, 4-20mA
Temperature measurement	None	None	None	None	None	None
<b>Outputs</b>						
Digital outputs	6 pnp (source)	8 pnp (source)	6 relay outputs	6 relay outputs	6 relay outputs	6 relay outputs
High-speed outputs/PWM	None	None	None	None	None	None
Analog outputs	None	One 10 bit output: 0-10V	None	None	None	None
<b>Program</b>						
Ladder code memory (virtual)	24K	24K	12K	36K	36K	36K
Execution time for bit operations	12µS	12µS	12µS	12µS	12µS	12µS
Bit/Coils	256					
Integers/Registers (16 Bit)	256					
Timers	64					
Database	1024 integers (indirect access)					
<b>Display</b>						
Type	STN LCD display, LED backlight					
Display size	1 line x 16 characters					
HMI displays	80 user-designed displays available					
Variables	50 HMI variables enable the conditional display & modification of text, numbers, dates, times & timer values. List Variables can add up to 120 conditional text messages.					
<b>Keypad</b>						
Number of keys	15 sealed membrane keys, including 14 programmable keys					
<b>Communication</b>						
Serial communications	RS232 port					
CANbus	None	Yes	None	None	Yes	Yes
GSM support	None	Enables SMS messages, containing text and variable data, to be communicated to and from 6 phone numbers. Up to 1K of user-defined messages.				
MODBUS	None	None	None			
<b>General</b>						
Power supply	24VDC	24VDC	24VDC	12/24VDC	12/24VDC	24VDC
I/O expansion option	Up to 64 additional I/Os		None			
PID	None	4 independent PID loops with Auto-tune <sup>4</sup>				
Clock (RTC)	Real-time clock functions (date and time)					

<sup>1</sup> M91-2-R34, M91-2-T38 and M91-2-RA22 are not yet UL certified.

<sup>2</sup> In these models certain inputs are adaptable, and can function as digital, analog, thermocouple or PT100 (model-dependent). Using adaptable inputs reduces the amount of free digital inputs. For example, using 2 TC inputs in M91-2-UA2 leaves 8 free digital inputs.



# 13 convenient M90/M91 models

M91-2-R34 <sup>1</sup>	M91-2-T1	M91-2-T38 <sup>1</sup>	M91-2-T2C	M91-2-UN2	M91-2-UA2	M91-2-RA22 <sup>1</sup>
20 Digital Inputs 12 Relay Outputs 2 Analog/Digital Inputs <sup>2</sup>	12 Digital Inputs 12 Transistor Outputs	22 Digital Inputs 16 Transistor Outputs	10 Digital Inputs 12 Transistor Outputs 2 Analog/Digital Inputs <sup>2</sup>	10 Digital Inputs 12 Transistor Outputs 2 PT100/TC/Analog/Digital Inputs <sup>2</sup>	10 Digital Inputs 10 Transistor Outputs 2 TC/Analog/Digital Inputs <sup>2</sup> 2 Analog Outputs	8 Digital Inputs / 8 Relay Outputs 2 Analog/Digital Inputs <sup>2</sup> 2 PT100/TC/Digital Inputs <sup>2</sup> 2 Analog Outputs
22 <sup>2</sup> pnp/npn (source/sink) 24VDC	12 pnp/npn (source/sink) 12/24VDC	22 pnp/npn (source/sink) 24VDC	12 <sup>2</sup> pnp/npn (source/sink) 12/24VDC	12 <sup>2</sup> pnp/npn (source/sink) 12/24VDC	12 <sup>2</sup> pnp/npn (source/sink) 24VDC	12 <sup>2</sup> pnp/npn (source/sink) 24VDC
Three 10 kHz, 16 bit resolution	Two 10 kHz, 16 bit resolution	Two 10 kHz, 16 bit resolution	Three 10 kHz, 16 bit resolution	Two 10 kHz, 16 bit resolution	One 10 kHz, 16 bit resolution	One 10 kHz, 16 bit resolution
Two <sup>2</sup> 10 bit inputs: 0-10V, 0-20mA, 4-20mA	None	None	Two <sup>2</sup> 10 bit inputs: 0-10V, 0-20mA, 4-20mA	Two <sup>2</sup> 14 bit inputs: 0-10V, 0-20mA, 4-20mA	Two <sup>2</sup> 14 bit inputs: 0-10V, 0-20mA, 4-20mA	Two <sup>2</sup> 14 bit inputs: 0-10V, 0-20mA, 4-20mA
None	None	None	None	Two <sup>2</sup> PT100 or Thermocouple inputs	Two <sup>2</sup> Thermocouple inputs	Two <sup>2</sup> PT100 or Thermocouple inputs
12 relay outputs	12 pnp (source)	16 pnp (source)	12 pnp (source)	12 pnp (source)	10 pnp (source)	8 relay outputs
None	First 2 outputs can function as HSO, 2 kHz maximum					None
None	None	None	None	None	Two 12 bit outputs: 0-10V, 4-20mA	Two 12 bit outputs: 0-10V, 4-20mA
36K	36K	36K	36K	36K	36K	36K
12μS	12μS	12μS	12μS	12μS	12μS	12μS
256						
256						
64						
1024 integers (indirect access)						
STN LCD display, LED backlight						
2 lines x 16 characters						
80 user-designed displays available						
64 HMI variables are available to conditionally display and modify text, numbers, dates, times and timer values. The user can also create a list of up to 120 variable text displays, totaling up to 2K.						
15 sealed membrane keys, including 14 programmable keys						
RS232/RS485 port (selectable)						
None	None	None	None	Yes	None	None
Enables SMS messages, containing text and variable data, to be communicated to and from cellular devices. Up to 1K of user-defined messages.						
Supports MODBUS protocol, Master-Slave						
24VDC	24VDC	12/24VDC	24VDC	12/24VDC	12/24VDC	24VDC
Up to 96 additional I/Os						
Independent PID loops, including internal auto-tune and ramp-soak programmer <sup>4</sup>						
Real-time clock functions (date and time)						

<sup>3</sup> Certain inputs can function as high-speed counters, shaft-encoder inputs, frequency measurers, or normal digital inputs.

<sup>4</sup> Internal auto-tune is available in M91 series. Auto-tune via an external PC-based application is available in M90 and M91 series.

